

FIELD DRAFT CONTROLS

www.fieldcontrols.com

INDEX

FIELD DRAFT CONTROLS	
TYPE M	7-7
TYPE MG-1	7-8
TYPE M+MG2	7-9
TYPE RC	7-6
INTRODUCTION	7-2 – 7-5

Expert Service. Quality Products. Since 1960.

FIELD DRAFT CONTROLS

www.fieldcontrols.com

FIELD DRAFT CONTROLS

For proper operation and efficient fuel consumption in oil, gas, and/or coal-fired heating appliances, draft must remain constant. When it is, combustion is more complete, fuels are utilized efficiently, and money is saved.

Field Draft Controls maintain consistent draft by counteracting the negative forces caused by changes in temperature and barometric pressure, as well as the effects of wind.



RC



MG-1



M



M+MG2

How Draft Controls Work

Static pressure of the cool air (1) Illustration A exerts pressure on the outside of the furnace or boiler, the breaching, and stack. The pressure difference between the room air and heated gas (air) causes products of combustion (2) to flow (draft) through the unit and rise through the breaching and chimney.

Room temperature air (3) enters through the barometric draft control (4) in the precise amount needed to overcome the excess drafts caused by temperature variations, wind fluctuations, and barometric pressure changes.

Combustion of fuel is complete and the process is stabilized. The velocity of combustion gases through the heat exchanger is slowed so more heat is extracted. The unit operates more efficiently, reliably, and requires less maintenance.

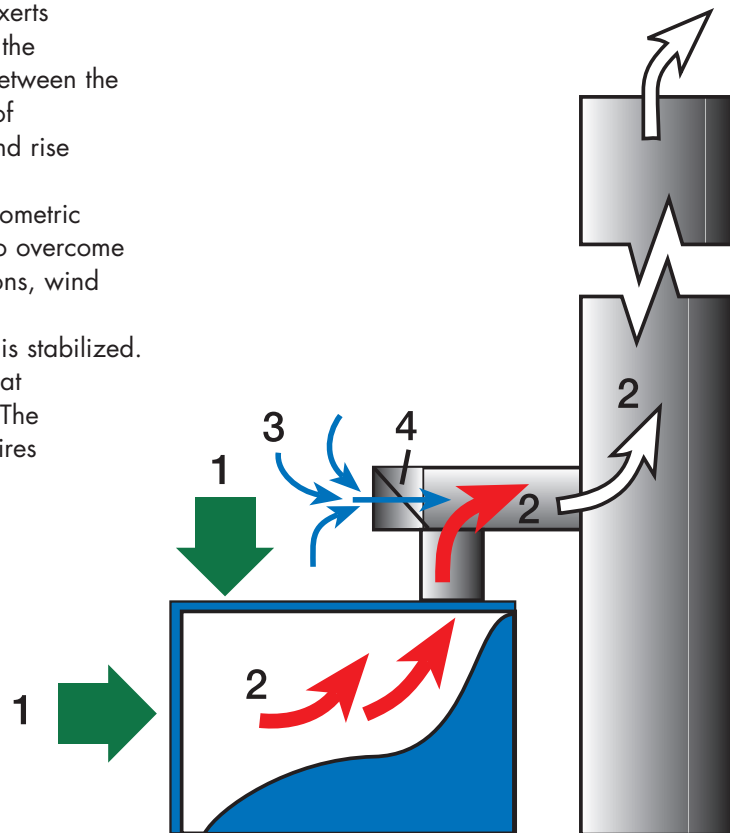

Illustration A
Gas Installation

FIELD DRAFT CONTROLS (cont'd)

Typical Natural Vent System

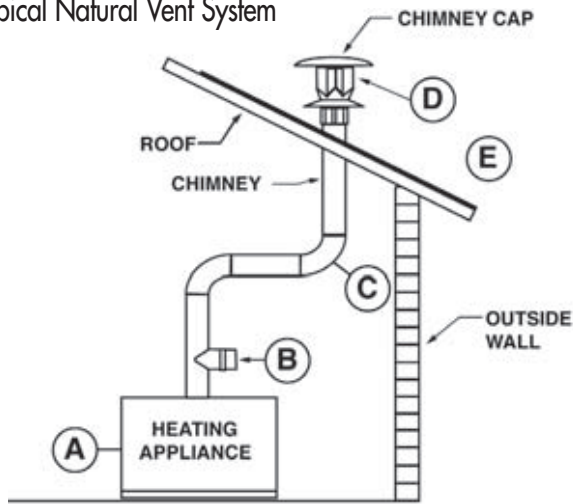

Illustration B demonstrates how pressure changes as air/gases flow through the appliance (A), past the draft control (B), through the vent pipe (C), and outside the building (D/E).

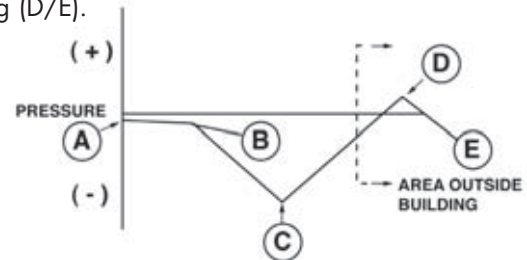

Illustration B

When to use a Draft Control

- **Draft Inducers/Power Venters**

With these devices, draft is increased or created, causing fluctuations in air flow through the combustion chamber. These fluctuations can be negated by the use of a barometric draft control located between the draft inducer or power venter and the furnace, boiler, or water heater it services. Use a single-acting control for oil and gas-fired equipment with a power vented system. Use a single-acting control for oil, and a double-acting control for gas-fired equipment with a draft induced system.

- **Power Burners**

A power burner is designed so that a fan delivers negative air pressure to the combustion chamber. A single-acting draft control for oil maintains that negative pressure.

A power burner designed to burn natural or LP gas operates in the same manner. While a draft hood (diverter) is often used on gas units fired with an atmospheric burner, a double-acting barometric draft control should be used for furnaces or boilers fired with power burners.

- **Forced Draft Burners**

Forced Draft installed with a stack height in excess of 30' will probably develop excessive natural draft, reducing the amount of pressure within the furnace

or boiler. A barometric draft control will help eliminate this undesirable stack action and permit the unit to be pressurized.

- **Dual Fuel Appliances**

Burners capable of burning either gaseous fuels or oil should be equipped with a barometric draft control. We suggest using a double-acting control on units where fuels are frequently changed. The double-acting feature is important for gas-firing appliances because it allows spillage of combustion products in case of blocked flues or down-drafts. To detect flue gas spillage on dual fuel installation, a Field Thermal Safety Switch is recommended.

- **Gas-Fired Appliances**

Gas-fired furnaces and boilers generally require a double-acting draft control. Like a single-acting control, it opens inwardly to maintain a uniform draft. But, unlike a single-acting control, it is also free to open outwardly to spill the products of combustion, in case of blocked flues or down-drafts.

National codes often mandate the use of a draft control. Usage is generally limited to furnaces or boilers designed for use with power burners and incinerators. Draft controls are generally used when oil-fired units are converted to gas.

FIELD DRAFT CONTROLS

www.fieldcontrols.com

FIELD DRAFT CONTROLS (cont'd)

Recommended Locations for Field Draft Controls
 For gas-fired equipment, the preferred location of the control is on the bull head tee. This location provides maximum relief of downdrafts with minimum positive pressure. (See Fig. 1, Dia. A-C)

With oil or solid fuels, the bull head tee is not recommended, so locate the control as shown. (See Fig. 1, Dia. D-J). These locations are acceptable for gas units as well. Except on forced draft systems, locate the control as close as possible to the furnace or boiler, at least 12" beyond a stack switch on oil-fired units, and at least 18" from a combustible ceiling or wall.

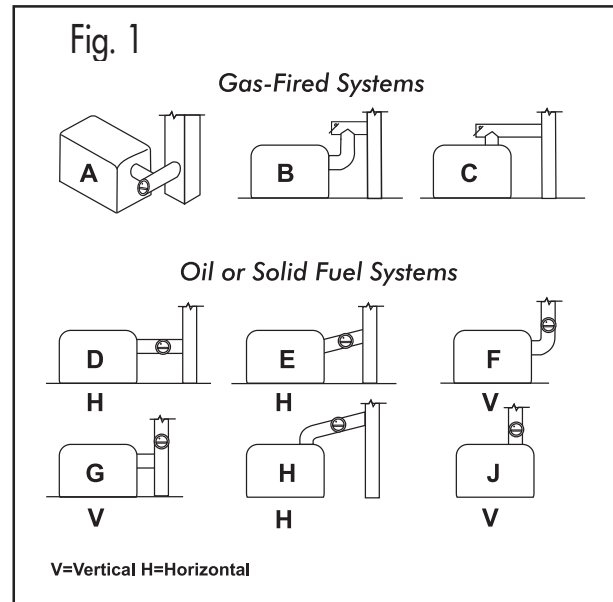

Multiple Appliance Location Recommendations

Commercial and industrial furnaces and boilers are frequently installed in multiples. (See Fig. 2)
 Use a draft control for each boiler located on the uptake between the smoke outlet and the breaching (location A). When this uptake is too short to permit the installation of a control, locate a separate control for each boiler on the main breaching (location B). If neither of these locations is possible, use a single large

control in the breaching between the chimney and the nearest boiler (location C).
 Where several units are vented into a common breaching, the most draft-critical should vent highest in, or be placed closest to the chimney. Incinerators should generally be placed farthest from, or vented lowest in the chimney.

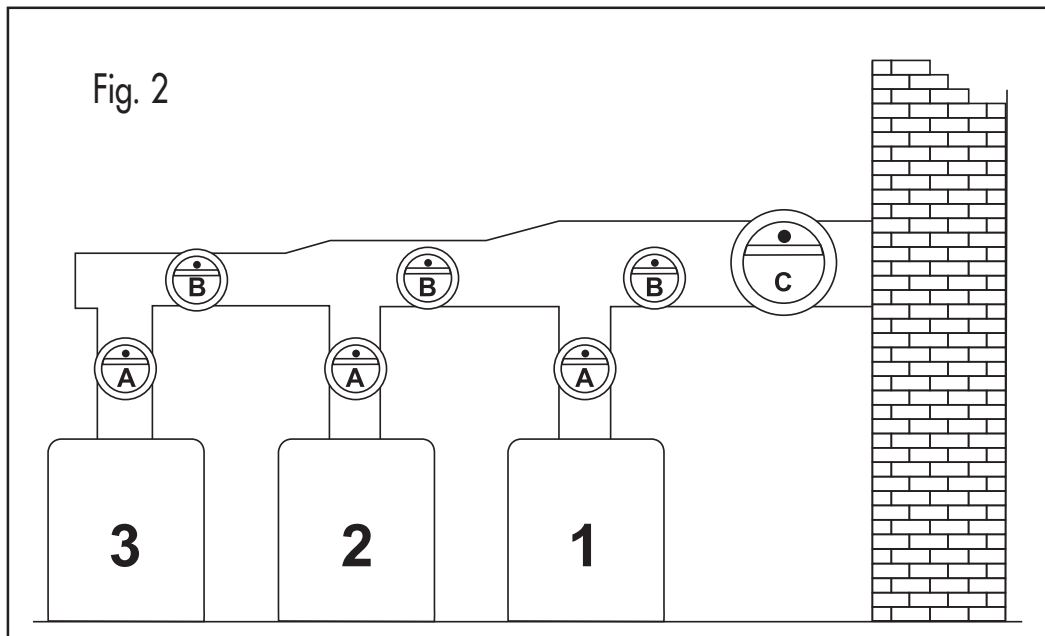

FIELD DRAFT CONTROLS

www.fieldcontrols.com

FIELD DRAFT CONTROLS (cont'd)

Choosing The Right Size

Simple rules of thumb to guide size selections:

- For most applications, the draft control should be the same size as the flue pipe. In other words, use a 6" control for a 6" pipe.
- If the flue pipe or breaching is square, use the round equivalent. For example - on a 14" x 14" breaching use a 14" control. Little flow occurs in the corners of a square pipe, so its capacity is approximately the same as a round pipe of the same diameter.
- If the breaching is rectangular or oval, compute its cross-sectional area and select a draft control having the same or a greater nominal cross-sectional area. A breaching 14" high x 10" wide would have a cross-sectional area of 140 square inches. From the table, select a 14" control with a cross-sectional area of 154 square inches.
- Where a control larger than 32" is required, use more than one draft control with combined cross-sectional areas equal to or greater than that of the breaching.
- When chimneys are of an unusual height, or if the draft to be maintained is either very high or very low, it is advisable to deviate from the rules of thumb outlined here and refer to the sizing chart.

Control Size	Nominal Cross-Sectional Area (Sq. In.)	Control Size	Nominal Cross-Sectional Area (Sq. In.)
6"	28	16"	201
7"	38	18"	255
8"	50	20"	314
9"	63	24"	452
10"	78	28"	616
12"	113	32"	804
14"	154		

Sizing Chart						
Diameter of Flue or Breaching	If Chimney Height is	Use This Size Control	If Chimney Height is	Use This Size Control	If Chimney Height is	Use This Size Control
4	15' or less	4"	16' or more	5"		
5	15' or less	5"	16' or more	6"		
6	15' or less	6"	16' or more	7"		
7	15' or less	7"	16' or more	8"		
8	15' or less	8"	16' or more	9"		
9	15' or less	9"	16'-30'	10"	31' or more	12"
10	20' or less	10"	21'-40'	12"	41' or more	14"
11	20' or less	12"	21'-40'	12"	41' or more	14"
12	20' or less	12"	21'-40'	14"	41' or more	16"
13	22' or less	14"	23'-45'	16"	46' or more	18"
14	22' or less	14"	23'-45'	16"	46' or more	18"
15	22' or less	16"	23'-45'	16"	46' or more	18"
16	30' or less	16"	31'-50'	18"	51' or more	20"
17	30' or less	18"	31'-50'	20"	51' or more	20"
18	30' or less	18"	31'-50'	20"	51' or more	20"
19	30' or less	20"	31'-50'	20"	51' or more	24"
20	30' or less	20"	31'-50'	20"	51' or more	24"
21	30' or less	20"	31'-50'	24"	51' or more	24"
22	30' or less	24"	31'-50'	24"	51' or more	24"
23	35' or less	24"	36'-60'	24"	61' or more	28"
24	35' or less	24"	36'-60'	24"	61' or more	28"
25	35' or less	28"	36'-60'	28"	61' or more	28"
26	40' or less	28"	41'-70'	28"	71' or more	28"
27	40' or less	28"	41'-70'	28"	71'-100'	28"
28	50' or less	28"	51'-100'	32"	100' or more	32"
29	50' or less	28"	51'-100'	32"	100' or more	32"
30	50' or less	32"	51'-100'	32"	100' or more	32"
31	50' or less	32"	51'-100'	32"	100' or more	Two 24"
32	50' or less	32"	51'-100'	32"	100' or more	One 24" One 28"
33	50' or less	32"	51'-100'	One 32" One 20"	100' or more	One 32" One 24"
34	50' or less	32"	51'-100'	One 32" One 24"	100' or more	One 32" One 24"

- E.&O.E. - All Prices F.O.B. Our Warehouse - Subject to Change Without Notice - All Taxes Extra - May not be Available at All Branches -

FIELD DRAFT CONTROLS

www.fieldcontrols.com

TYPE RC

Oil or Coal – Residential and Commercial

The Field RC is furnished as standard equipment on many leading brands of oil or coal-fired heating equipment. It is calibrated to allow for easy adjustment to the furnace or boiler manufacturer's specifications.

Designed for settings from .02" to .08", this control is so sensitive that instrumentation should be used when adjusting the unit during installation.



ITEM #	MODEL
760567	4" RC
760568	5" RC
760563	6" RC
760564	7" RC
760565	8" RC
C750000	9" RC

Model	Control Size	Nominal Capacity Sq. In.	Recommended Pipe Sizes (in.)		Dimensions (inches)							
			Dia.	Circum.	A	B	C	D	E	G	H	M
4" RC/RCBT	4	12.6	3-4-5	9 ½ to 15 ¾	4	2 ½	2	2 ⅝	4 ⅝	1	2 ½	7
5" RC/RCBT	5	19.6	4-5-6	12 ½ to 19	5	2 ½	2	2 ⅝	5 ⅝	1	2 ½	7
6" RC/RCBT	6	28.3	5-6-7	15 ¾ to 22	6	1 ⅞	3	2	6 ⅞	1	2 ¾	7 ⅞
7" RC/RCBT	7	38.5	6-7-8	19 to 25 ¼	7	2 ⅞	3 ½	2 ½	7 ⅞	1	2 ¾	8 ⅞
8" RC/RCBT	8	50.3	7-8-9	22 to 28 ⅝	8	4 ⅞	4	3 ⅞	8 1 ⅝	1 ⅞	2 ⅞	11
9" RC/RCBT	9	63.6	8-9-10	25 ¼ to 31 ½	9	5 ⅞	4 ½	3 ¾	9 1 ⅝	1 ½	2 ⅞	12 ¼

*RCBT is recommended for wood and coal burning applications or anytime black pipe is preferred.

MATERIAL GAUGES

Size	4"	5"	6"	7"	8"	9"
RING	22	24	24	22	20	20
GATE	24	24	24	24	20	20
COLLAR	26	26	26	26	26	26

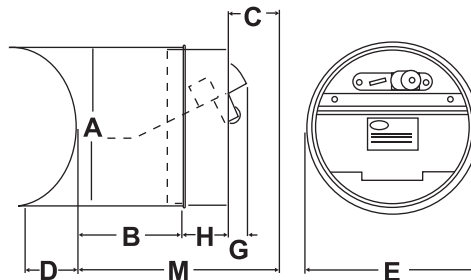

FIELD DRAFT CONTROLS

www.fieldcontrols.com

TYPE M

Oil or Coal - Residential

The M control lends itself ideally to conditions requiring a great deal of stability and accuracy. Designed for settings from .01" to .1", the Field M Control is recommended for oil or coal-fired residential heating applications. The Type M features an infinitely variable screw adjustment, permitting an extremely fine instrument setting. The M employs side wings to control air direction with gate curvatures designed to compensate for differences in horizontal and vertical settings.



Model	Control Size	Nominal Capacity Sq. In.	Recommended Pipe Sizes (in.)		Dimensions (inches)						
			Dia.	Circum.	A	B	C	D	E	G	M
6" M	6	28.3	5-6-7	15 3/4 to 22	6	5	3	3 1/4	6 1/2	2	8
7" M	7	38.5	6-7-8	19 to 25 1/4	7	5 1/4	3 1/2	3 3/4	7 5/8	2 1/4	8 3/4
8" M	8	50.3	7-8-9	22 to 28 1/4	8	6 5/8	4	3 5/8	8 5/8	3	10 5/8
9" M	9	63.6	8-9-10	25 1/4 to 31 1/2	9	7 1/4	4 1/2	3 3/4	9 5/8	1 2/32	11 1/4

MATERIAL GAUGES

Size	6"	7"	8"	9"
RING	24	22	20	20
GATE	26	22	20	20
COLLAR	26	26	24	24

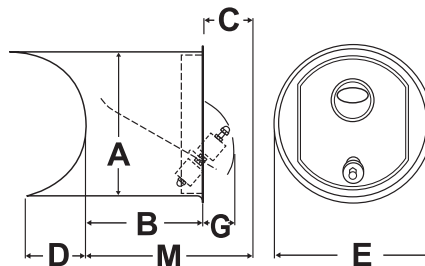

FIELD DRAFT CONTROLS

www.fieldcontrols.com

TYPE MG-1

Gas

A double-acting control for gas-fired furnaces and boilers is widely used for conversion burner installations, gas draft-induced appliance operation with mechanical draft inducers, or sidewall power venters. It is also recommended for use on gas atmospheric appliances where a draft hood cannot be installed, and can improve combustion stability and draft on many gas atmospheric installations with venting problems.

The MG-1 provides precise, accurate control of drafts at levels higher than permitted by a standard draft diverter, which is a frequent requirement with gas. Because it is double-acting, it opens out to relieve positive vent system pressures as low as .01". Draft adjustments using weights are simple and accurate from .01" to .1".

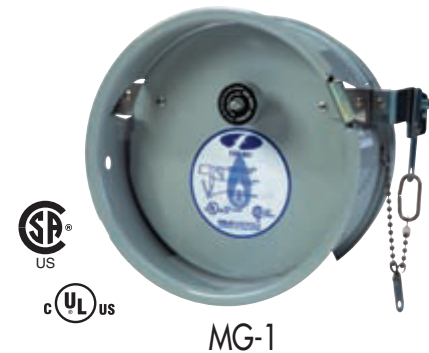

ITEM #	MODEL
760558	4" MG1
760559	5" MG1
760560	6" MG1
760561	7" MG1
760562	8" MG1
C750000	9" MG1

Model	Control Size	Nominal Capacity Sq. In.	Recommended Pipe Sizes (in.)		Dimensions (inches)												
			Dia.	Circum.	A	B	C	D	E	F	G	H	J	K	L	M	
4" MG-1	4	12.6	3 - 4	9 ½ to 12 ½	4	2 ½	2	2 ⅝	4 ⅝	1 ½	¼	2 ½	½	1 ¼	⅝	7	
5" MG-1	5	19.6	4 - 5	12 ½ to 15 ¾	5	2 ½	2	2 ⅝	5 ⅝	2	⅝	2 ½	½	1 ¼	½	7	
6" MG-1	6	28.3	5 - 6	15 ¾ to 19	6	2 ⅞	3	3 ¼	6 ⅝	2 ⅝	1 ⅝	2 ¾	¾	1 ¾	⅝	8 ⅞	
7" MG-1	7	38.5	6 - 7	19 to 22	7	3 ⅜	3 ½	3 ¾	7 ⅝	2 ⅝	1 ⅝	2 ¾	¾	2	¼	9 ⅝	
8" MG-1	8	50.3	7 - 8	22 to 25 ¼	8	4 ⅝	4	3 ⅝	8 1 ⅞	3	1 ½	2 ⅝	¾	2 ¼	⅝	11	
9" MG-1	9	63.6	8 - 9	25 ¼ to 28 ¼	9	5 ⅝	4 ½	3 ¾	9 1 ⅞	3 ½	1 ¾	2 ⅝	¾	2 ½	⅝	12 ¼	

MATERIAL GAUGES

Size	4"	5"	6"	7"	8"	9"
RING	24	24	24	22	20	20
GATE	24	24	24	22	20	20
COLLAR	26	26	26	26	26	26

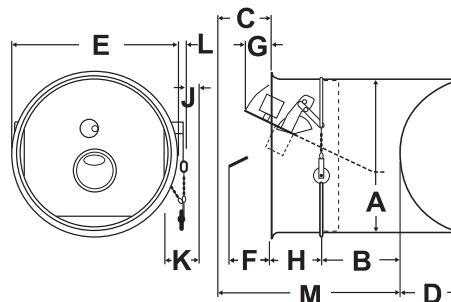

FIELD DRAFT CONTROLS

www.fieldcontrols.com

TYPE M+MG2

Solid, Oil or Gas Commercial/Industrial

This is a series of compact, rugged, heavy-duty controls for use on large residential, commercial, and industrial applications. The Field Type M+MG2 Draft Control provides precise draft regulations for solid fuels, oil, gas, or oil/gas appliances requiring only the simplest, on-the-job adjustments depending on which fuel is to be utilized. In a gas installation, the double-acting Type M+MG2 is specified instead of a draft hood to give the appliance the assistance of the chimney. In a dual fuel oil/gas or a gas-fired only application, use the M+MG2 as a double-acting draft control with the optional Field Thermal Switch accessory. Use the M+MG2 as a single-acting draft control for oil or solid fuel applications. For any installation with 10" or larger diameter smoke pipe, specify our standard M+MG2 Draft Control, the unit that can be adapted to any fuel.

The moving part (gate) rests on a long, thin, stainless steel knife edge which, in turn, is supported by self-aligning and self-cleaning bearings. When the heavy gauge gate moves, only the knife edge rests on the bearing for minimum friction and maximum sensitivity to draft changes.



M+MG2



ITEM #	MODEL
760581	10" M+MG2
760582	12" M+MG2
760584	14" M+MG2
760586	16" M+MG2
C750000	18" M+MG2

Model	Control Size	Nominal Capacity Sq. In.	Recommended Pipe Sizes (in.)		Dimensions (inches)											
			Dia.	Circum.	A	B	C	D	E	F	G	H	J	K	L	M
10" M+MG2*	10	78.5	9 - 10	28 ¼ to 31 ½	10	4 ¾	5	4 ¼	11	3 ¾	1 ½	4 ¾	1	3 ½	1	14 ½
12" M+MG2*	12	113	11 - 12	34 ½ to 37 ¾	12	5 ¾	6	5	13 ¼	4 ¾	1 ¾	4 ¾	1	3 ½	¾	16 ½
14" M+MG2*	14	154	13 - 14	40 ¾ to 44	14	7 ½	7	5 ¾	15 ½	5 ¾	2 ½	5 ¾	1	3 ½	¾	19 ¼
16" M+MG2	16	201	15 - 16	47 to 50 ¼	16	8 ¾	8	6 ½	17 ½	6 ¾	2 ¾	5 ¾	1 ½	4	¾	22
18" M+MG2	18	255	17 - 18	53 ½ to 56 ½	18	8 ¼	9	7 ½	19 ½	6 ¾	2 ¾	7 ¾	1 ½	5 ¼	1 ¾	24 ¾
20" M+MG2**	20	314	19 - 21	59 ¾ to 66	20	9 ¾	10	8 ¾	22	7 ¾	3	7 ¾	1 ½	6 ¼	1 ¼	27 ¾
24" M+MG2**	24	452	22 - 25	69 to 78 ½	24	12 ¾	12	10 ½	26	9 ¼	3 ¾	8 ¾	2	6 ¼	1 ¼	33
28" M+MG2**	28	616	26 - 30	81 ¾ to 94 ¼	28	13 ¾	14	-	30 ½	10 ¾	4 ¾	11 ¾	2	6 ¼	¾	38 ½
32" M+MG2**	32	804	31 - 34	97 ½ to 107	32	15 ¾	16	-	35	12 ¼	4 ¾	12 ¾	2	6 ¼	¾	43 ½

*CSA certified

**An increaser or reducer may be necessary in order for the Barometric Draft Control to adapt to off-sized pipe.

MATERIAL GAUGES

Size	10"	12"	14"	16"	18"	20"	24"	28"	32"
RING	20	20	20	18	18	18	18	16	16
GATE	18	16	16	16	16	16	14	14	14
COLLAR	24*	24*	22*	20*	20*	18*	18*	14**	14**

*Galvanized

**HRPO with Enamel Finish

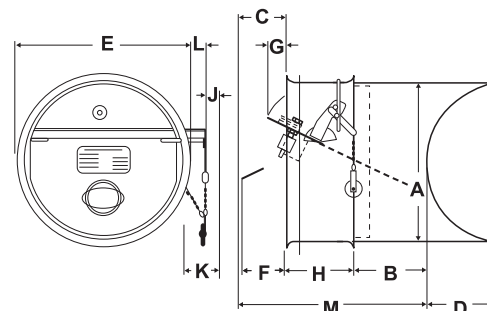

- E.&O.E. - All Prices F.O.B. Our Warehouse - Subject to Change Without Notice - All Taxes Extra - May not be Available at All Branches -